

PROVIDING THE BEST  
**VERTICAL TRANSPORTATION**

---



AN ISO 9001:2008 COMPANY

**GULF**<sup>™</sup>  
**ELEVATORS**  
From Excellence to Perfection



FROM EXCELLENCE  
**TO PERFECTION**

Industry leader providing innovative, reliable, and customized elevator solutions for diverse applications.

---

**BUSINESS**  
PROFILE

---

TAKING YOU  
TO THE  
**NEW HEIGHTS**

**Rise to  
your project's  
demands.**

**Get what you seek.  
Choice.  
Quality.  
Custom Features.  
Cost-effectiveness.  
Service.  
Value.**



# Table of Content

About us	04
Services	06
Traction Elevator System	09
Capsule Elevator	11
Automatic Elevator	13
Manual Elevator	15
Hospital Elevator	17
Freight Elevator	19
Automobile Elevator	21
MRL Elevator	23
Home Elevator	25
Hydraulic Elevator	27
Automatic Door System	29
Manual Door System	31

## ABOUT US

GULF Elevators provides affordable and best quality home elevators. With a team of specialist and expert engineers, we provide services for all types of commercial, residential and industrial spaces focusing on superior quality and affordability while catering to our clients simple and elegant design needs.

GULF Elevators provides affordable and best quality home elevators. With a team of specialist and expert engineers, we provide services for all types of commercial, residential and industrial spaces focusing on superior quality and affordability while catering to our clients simple and elegant design needs.

Established in 2012, GULF Elevators installs, maintains and modernizes elevators. With over 600 clients and over 2000 successful installations we are well equipped with technical know-how and practical solutions for custom requirement various segment presents.

Team based organizational structure lead by Mr Mohit Patel, MD young, energetic and passionate with a goal to provide best riding experience to our client has inspire us to rise above the expectations of everyone. Quality and customer satisfaction are not just the statement but core belief of our workplace.

**SET YOUR GOALS HIGH,  
AND DON'T STOP TILL YOU  
GET THERE.**



### WHY SHOULD YOU CHOOSE GULF LIFTS?



PREMIUM QUALITY



HASSLE-FREE MAINTENANCE



TRANSPARENT PRICING



CUTTING EDGE TECHNOLOGY

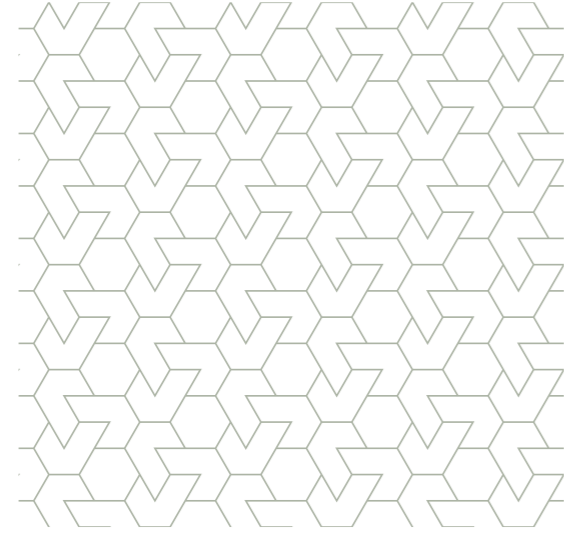

### Our Vision

To give people freedom to connect and thrive in a taller, faster, smarter world.



### Our Mission

To be a world-class, customer-centric, service-oriented company.



### Our Value

We put people at the centre of everything we do. We are reliable, smart and focused on the future. We are creating a more personal, connected world.

## SERVICES

What would be your worst nightmare when you stay on the 20th floor of a building? An "out of order" sign taped to its elevators! The most crucial part of elevator systems in our buildings begin after the lift is installed - its maintenance.

With GULF's adaptive elevator maintenance process, you can stop worrying about "out of order elevator". A regular maintenance and health check-up of the elevator helps to periodically assess and enforce protective mechanisms to your elevator machinery to avoid emergency breakdowns and prolong the life and overall performance of the elevator.

With several elevator service providers out there, it becomes difficult to choose one service and maintenance company that best suits your requirements.

### Here are 5 key things to look out for when choosing an elevator service and maintenance company

#### 1. Do they have prior experience and expertise?

A company's prior experience, expertise, and work will tell you about the kind of service they provide and the value they add to their customer's experience.

#### 2. What are their safety standards and precautions?

For safety precautions, it is important that you hire a service company that is fully certified. It is crucial to know they follow all the safety guidelines and standards to ensure the optimum security of your people.

#### 3. Are they well-equipped with the latest technologies?

Look for technologies that will make yours and your tenant's life easy, such as, destination control systems, communicative elevators driven by IoT systems, etc. Also, go with teams that offer futuristic installation and maintenance techniques.

#### 4. Do they have skilled technicians?

Ensure the company has well-trained, skilled and experienced technicians who can understand your elevator requirements and provide the best engineering solutions to keep your system running smoothly.

#### 5. Do they have 24/7 service?

You never know when you may need emergency repairs. Look for a company that provides 24/7 customer support so that you're never left stranded waiting for a response. You should have the peace of mind that your need will be attended to at any time of the day.

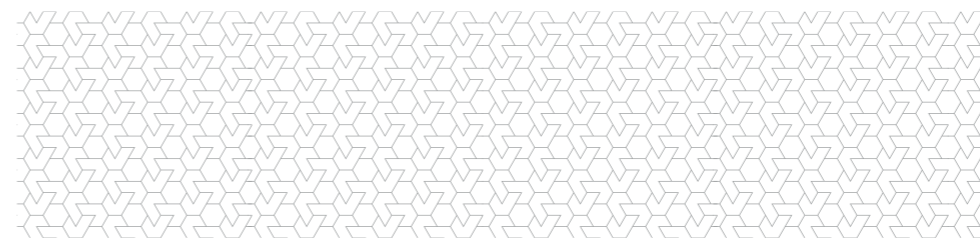
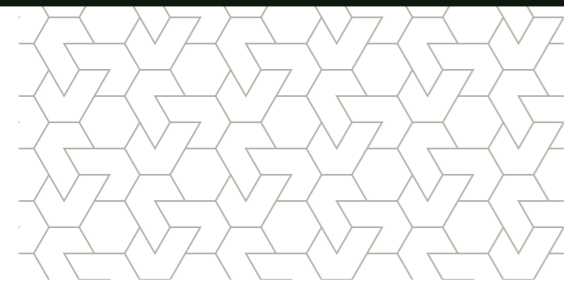

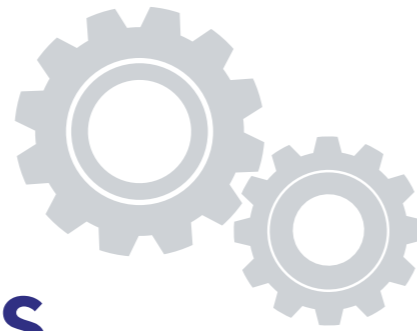

## SERVICES

GULF ticks all the boxes of the key things you should look out for while choosing your elevator service and maintenance company.

GULF Elevators has been providing repair and maintenance services to keep your equipment running safely and reliably for the past 14 years. The annual maintenance contracts offered by GULF can be customised individually to meet your specific building requirements, equipment conditions, and more.



**GULF's Customer Service Network is staffed with trained associates to help you 24/7 when you need to call for service.**



**GULF prides itself in servicing with the original equipment manufacturer and providing genuine parts and spares manufactured in India.**



**GULF has only the best-trained technicians in the industry who spend a considerable amount of time honing their skills at GULF's world class training facilities at Ahmedabad and Rajkot.**

**GULF technicians are equipped with GULF Connect which allows them to access repair history, technical data, trouble-shooting guide, repair routines, etc. and their years of experience in the field, they are capable of providing expert engineering support on the local, regional and national level to keep your systems moving**

Customer and product safety are a top priority at GULF. Our commitment to excellence service, adaptive maintenance programs with state-of-the-art technology and highly trained technicians assures the same. Choosing GULF means fewer call-backs and fewer inconveniences for your tenants and guests.

Choosing a service maintenance company can be daunting but once you have the right one, you have the assurance of the safety of your tenants and guests.

# We succeed by being a good corporate citizen

With customers in approximately 60 cities and territories, GULF is a true corporate citizen.

Everywhere we do business, we operate on the belief that financial performance and corporate responsibility go hand in hand.

We see corporate citizenship as both an ethical responsibility and a business imperative – and embrace the idea that to do well, we must also do good. It's why we invest in our local communities, encourage employee volunteerism, aim to minimize our environmental footprint, nurture a workplace culture of diversity and inclusion, and uphold the highest standards of safety, ethics and quality.

**As we strive to give people freedom to connect and thrive in a taller, faster, smarter world, we're also committed to making life better everywhere we do business.**



### Safety

We may be in the business of making a taller, faster, smarter world, but we never take shortcuts to get there. So, whether it's building, installing or servicing our technology, or the public riding on it, safety comes before anything else at GULF.



### Ethics

Millions of people, from customers and end users, to employees and passengers, trust us because they know we do business the right way. – the ethical, lawful and honest way



### Quality

We stand for outstanding quality – from engineering, manufacturing, installation and service to selling, marketing and reporting on financials. We want GULF to be the best. That requires everyone to work together with the same commitment to quality and focus across the entire organization.

## Traction Elevator System

When you need to move a lot of people in a little time – economically, comfortably and reliably - you need a traction elevator. Ideal for high and medium-rise buildings. Traction elevator delivers smooth, quick acceleration, energy efficiency and attractive cost for high-rise buildings. Especially, these lifts impress with their versatility, power and speed. A superior combination of flexibility and performance. To create the highest quality traction elevators, our designers and engineers put their technological creativity to its full potential. Our traction elevators combine the latest digital technology with world-renowned construction to achieve a new level of precision, energy efficiency, safety and reliability.

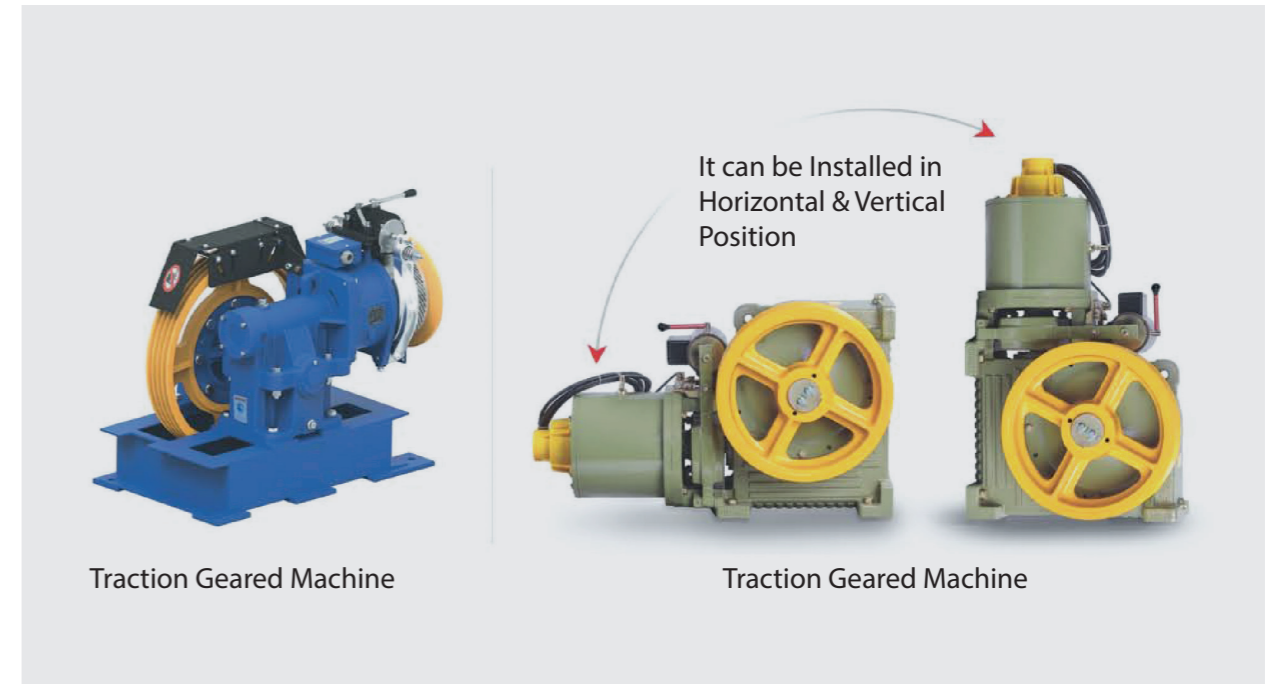
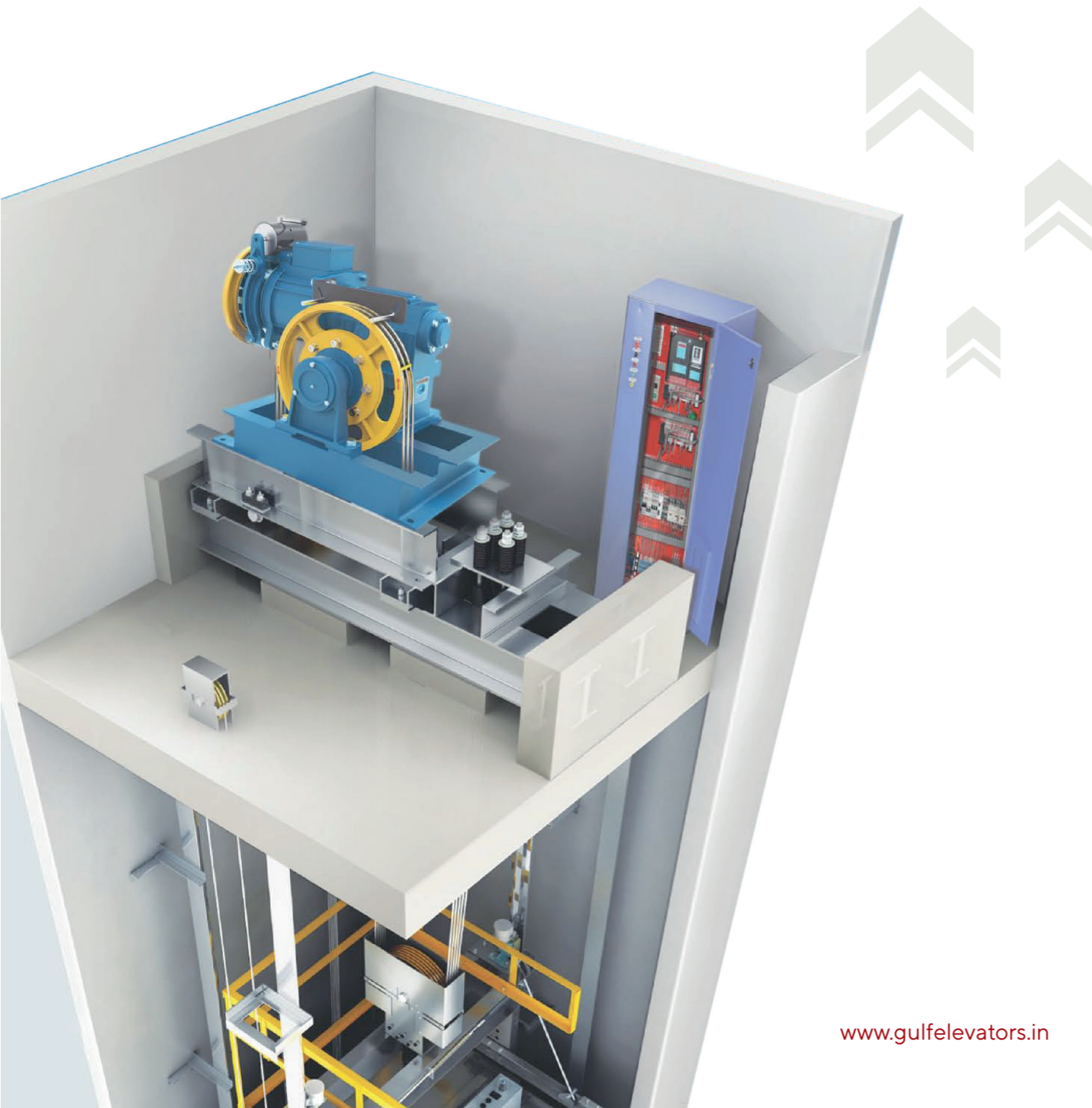

- » The traction elevator system is the most popular due to its flexibility.
- » Choose between two types of traction lifts: geared and gearless.
- » The geared traction lift is composed of 2 parts: the gear box and the electric motor.
- » The machinery may be located at the top of the building, or in the basement.
- » If you need a high-speed elevator in high-rise building, a traction elevator is your only choice.
- » Capitalizing on advances in motion control technology (Variable Voltage Variable Frequency), a frequency inverter smoothes the starts and stops of the cabin and conserves energy.

**Using high quality gear drive machines and V3F drives, these lifts' performance is of the highest standard.**



It purifies the power grid environment



It improves the machine room temperature



Above 30% of energy-saving



## Features of the Capsule Elevators

- » Made from S.S./M.S. with vision panel. Color-Powder coated, Elegant looks, Light in weight and variable speed.
- » Controller Full Proof to voltage (PLC or Sold state) with fully collective- selective system.
- » AC WVF drive for jerk free operation & for variable speed.
- » Overload indication and Auto Door announcing system.
- » Avail Inverter facility for single base at time of Power failure.
- » Push Button Luminous type highly attractive as well as durable.
- » Facility Floor Position Indication at the floors as well as in cabin.

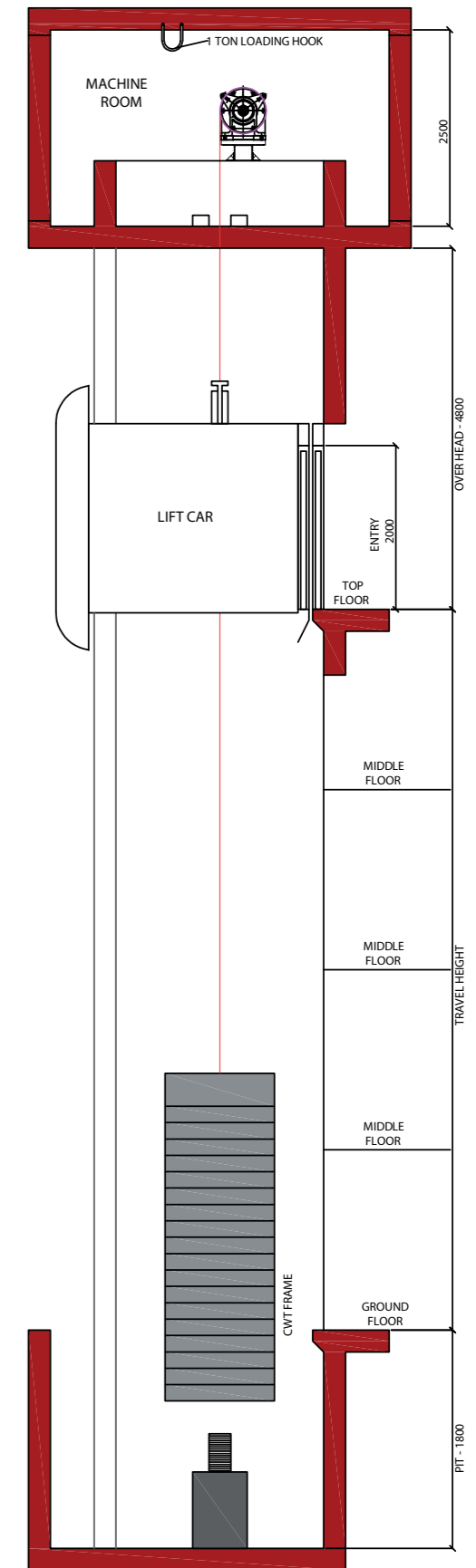

## Capsule Elevator

Glass capsule elevators give an upscale, attractive feel to offices, shopping malls, multiplexes and other prestigious buildings. These lifts owe their stunning looks to the large glass viewing panels which provide entertaining ride to passengers

Capsule elevators work just as well as small personal lifts for private homes as they do in large office and commercial buildings. Installation on the exterior face of the building or in the lobby will totally change the look of a building. And of course, they incorporate state-of-the-art technology.

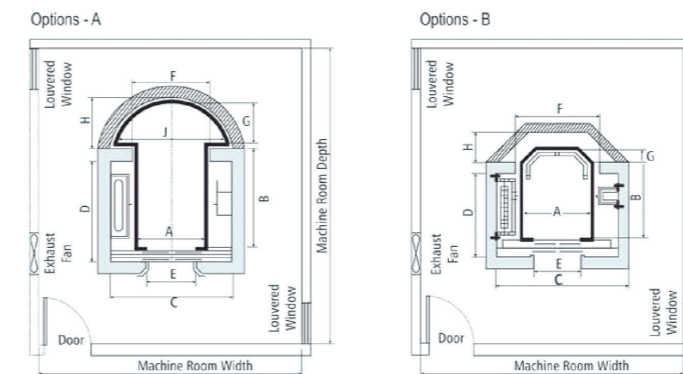

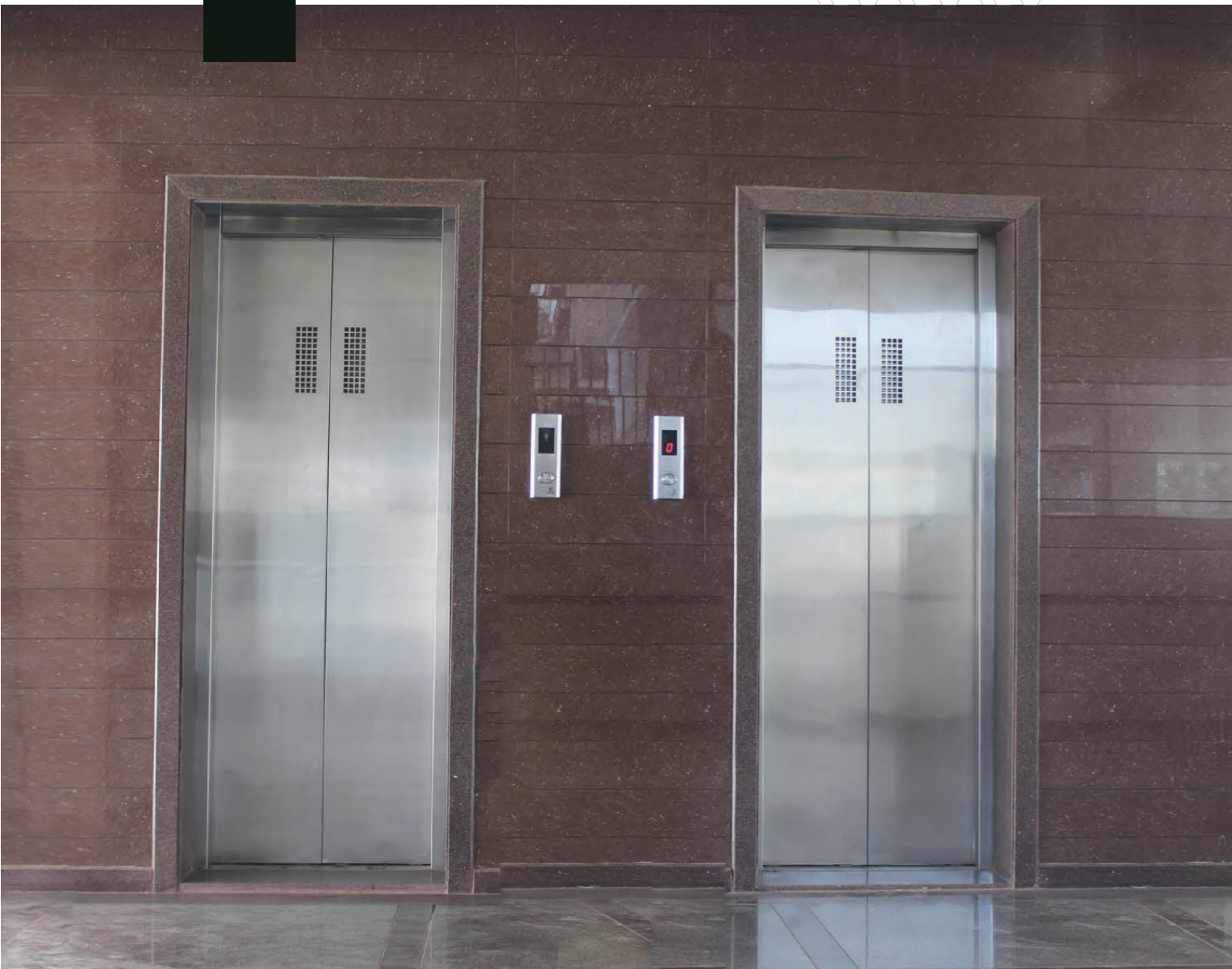

## Automatic Elevator

Whether you are planning for a high rise, high performance, high speed or simply high specification solution. we offer a range of elevators and innovations that were developed with these needs in mind.

Hoistway Machine Room Plan For Auto Door

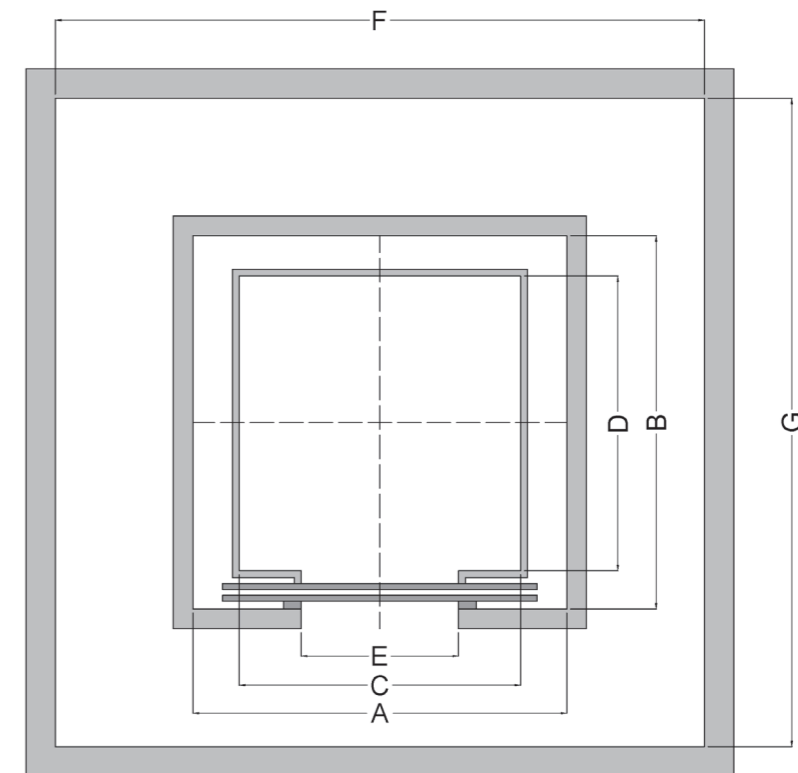

Elevators are the main transportation arteries in the modern building and are Vital in determining a building's economic success. We manufacture all types of passenger lifts of different capacity and speed. Our latest passenger lifts comprises of V3F Close & open loop microprocessor Controller with sophisticated steel car & latest electronic components that has low power consumption and are also maintenance free. We offer different types of cabins using material such as M.S.. S.S.. Glass. We provide latest version of Auto doors for cabin and landings which are specially designed in Germany with superior technical precision.

Infrared Light Curtain Protection

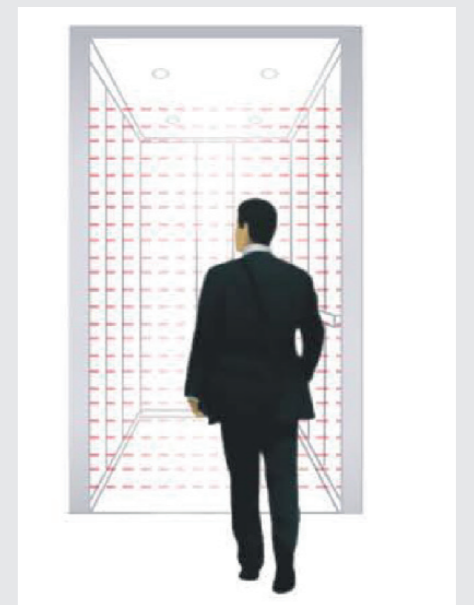



## Manual Elevator

GULF Manual door elevators are durable by design and accurate by technology. We have a wide range of these elevators which are most reliable and designed to suit every construction requirement and provide best vertical transportation solutions, with trouble free performance and low maintenance cost. These elevators are a perfect blend of Cost friendly and robust performance elevator applications. They have an excellent record of customer satisfaction.

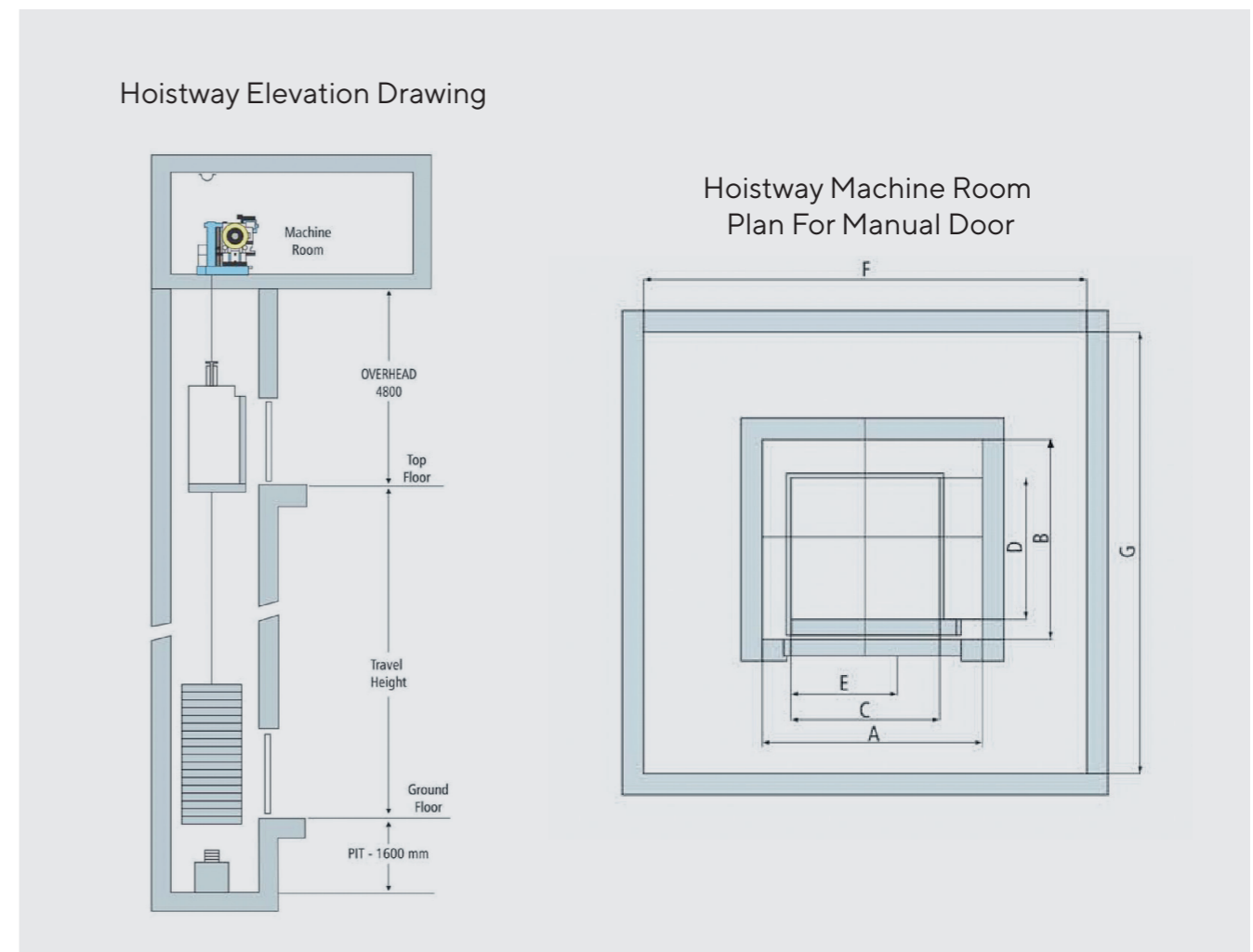

- » The passenger elevators detailed here are designed to handle promptly and efficiently the vertical transportation requirements of any type of building considering any traffic condition.
- » Delivers maximum lifting power with a minimum of effort.
- » A superior combination of flexibility and performance.
- » It gives benefits of jerk-less traveling, economically low power consumption and excellent design.





## Hospital Elevator

Hospital Elevators provide easy transportation of patients and bulky medical equipment such as gurneys, stretchers and wheel chairs. These lifts feature sophisticated looks and operated smoothly. Hospital Elevators are available in a wide variety, capable of carrying between 15 to 26 passengers at a time. These elevators usually feature center opening telescopic poweroperated doors and easy to use for people

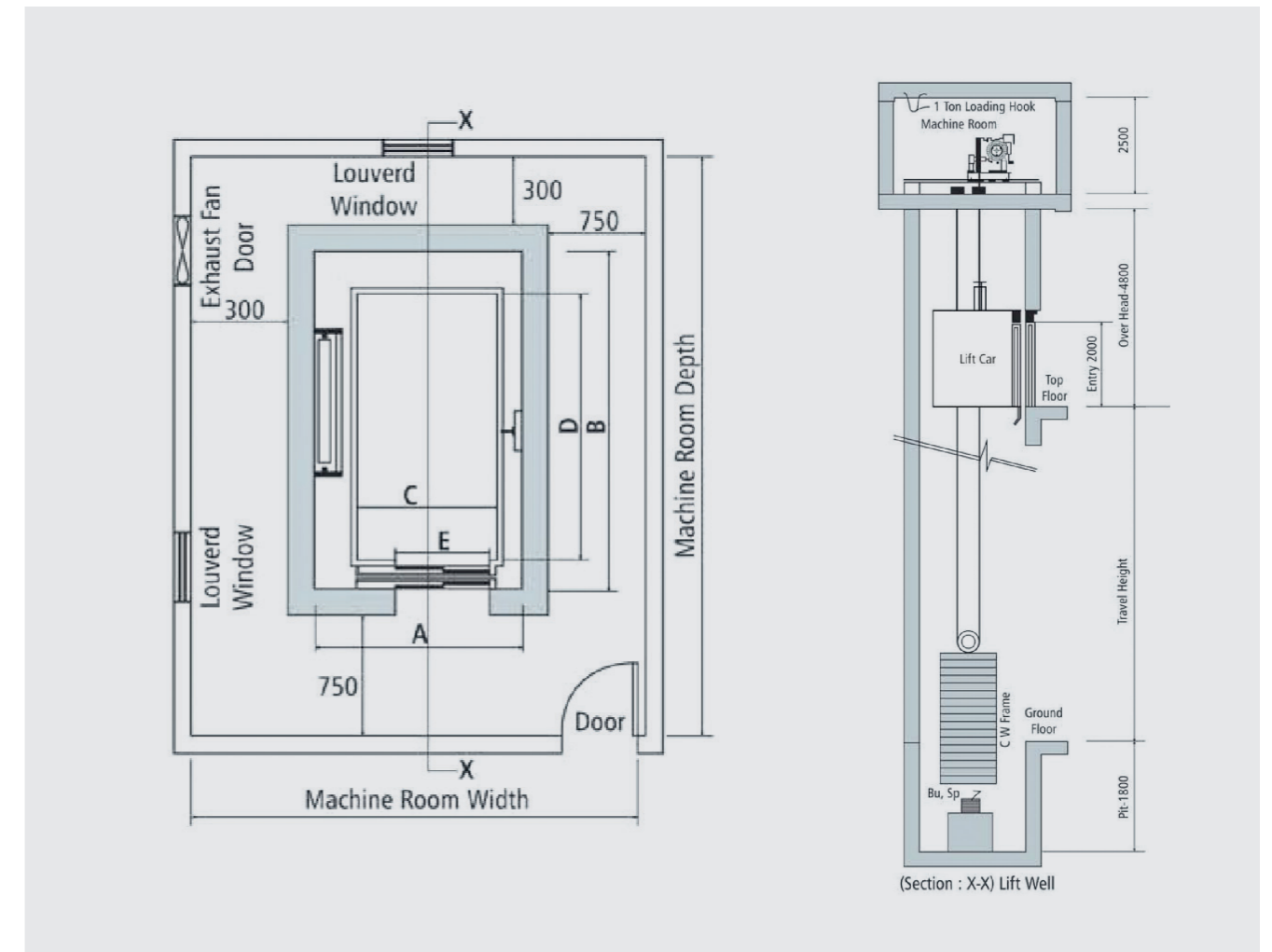

### Intellectual Control

It applies radiation-free integrated control cabinet that combines contemporary industrial control technology with communication technology. All steel plate enclosed design shields radiation. It is convenient in maintenance. WVF variable frequency control door machine system freely adjusts door machine running curve. It is safe in operation and stable in quality.

### Noise Reducing

It combines with low noise traction machine design, car wall triple noise reducing technologies, running system noise reducing design. Elevator operational noise is less than 43dB. It does not affect your family's sleeping and rest.

### Smooth and Comfortable

Smooth running system is specially designed for the old. The most comfortable speed running curve, smooth and soft start / stop are more suitable for use of old people.

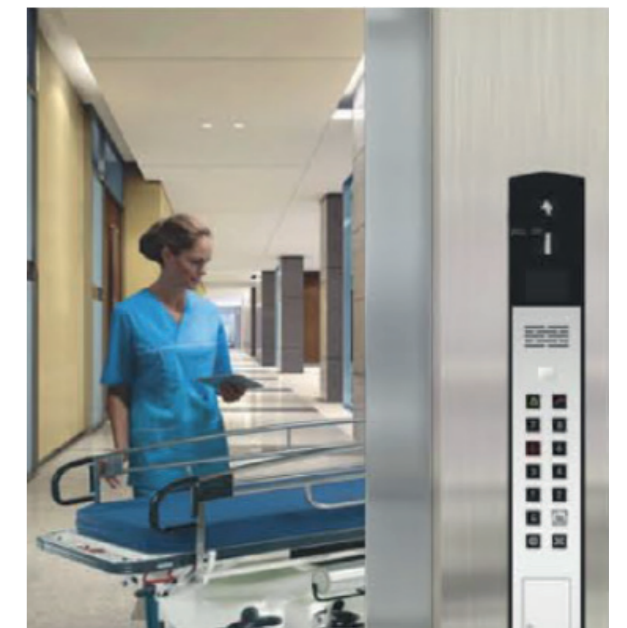

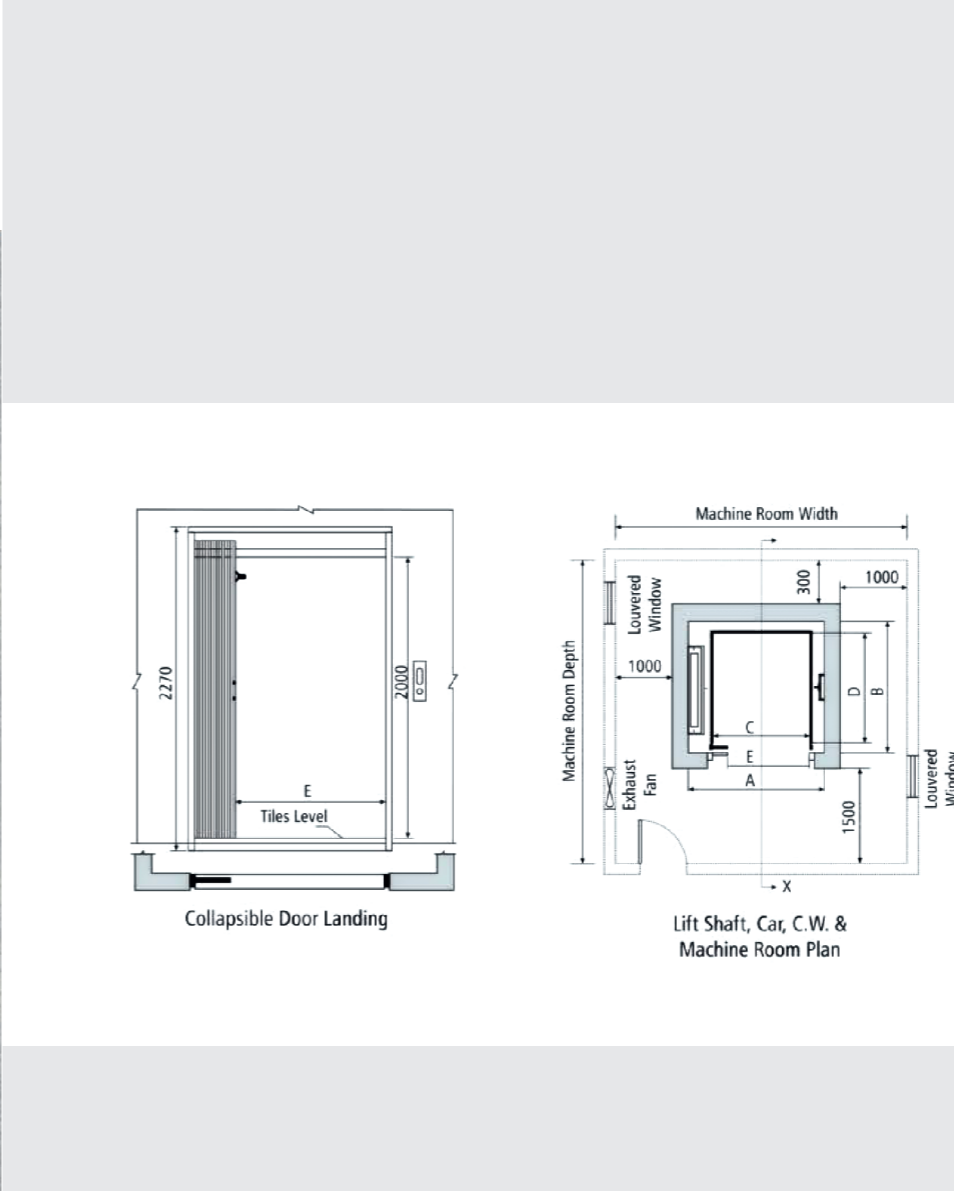

**Optimized intellectual properties  
Bear any heavy load at easy**

## Freight Elevator

A freight elevator is used to carry goods only, though some do both to allow operators and those loading goods along for the ride. Freight elevators are typically larger and capable of carrying heavier loads than a passenger elevator, generally from 2,300 to 4,500 kg. Freight elevators have manually operated doors and often boast rugged interior finishes to prevent damage while loading and unloading. Although hydraulic freight elevators exist, electric elevators are more energy-efficient for the work of freight lifting.

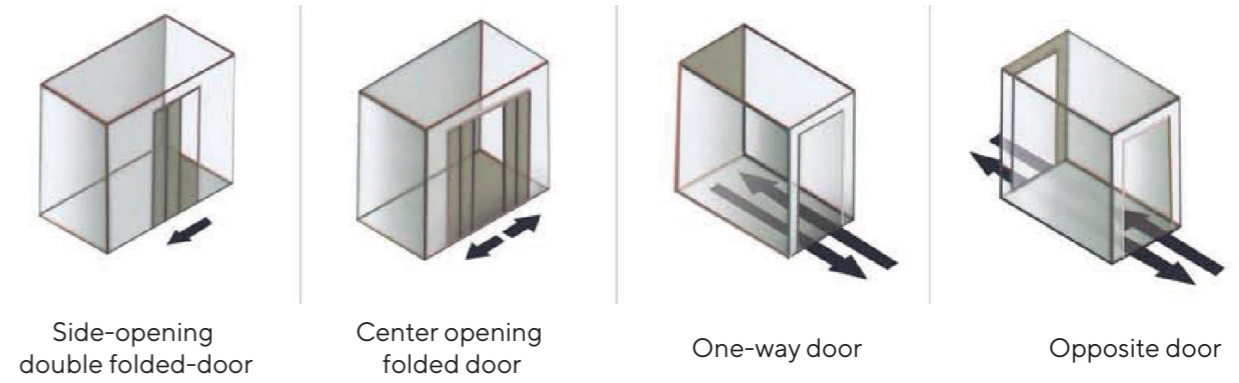

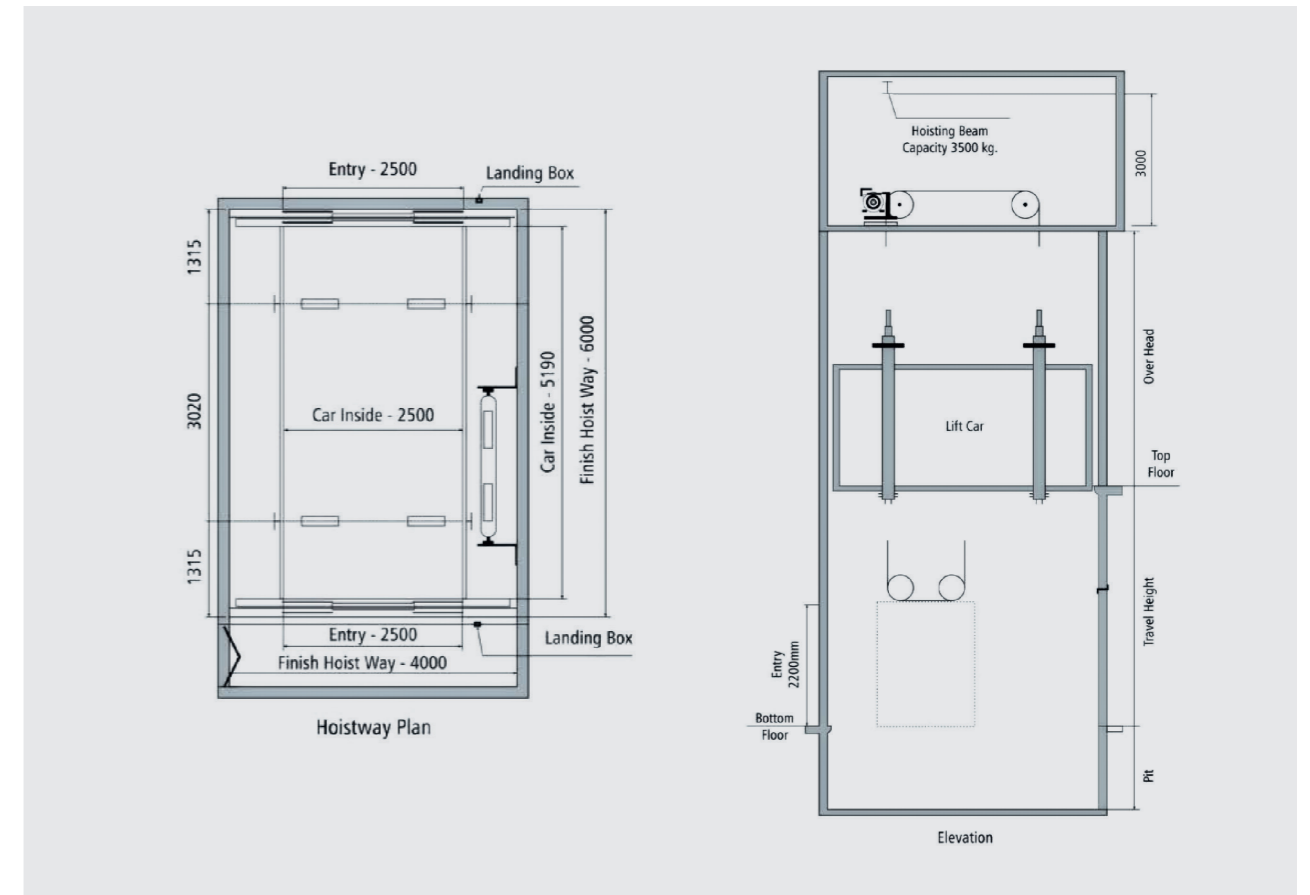

## Automobile Elevator

New Level of Parking Freedom Car elevators help to alleviate the problems of finding sufficient parking space in busy areas, and save on costly land in commercial spaces, These lifts smoothly transport vehicles to the tops of buildings, or to basements and showrooms. They are carefully engineered for independent access of vehicles in private homes or multi-family residences where space is valuable.

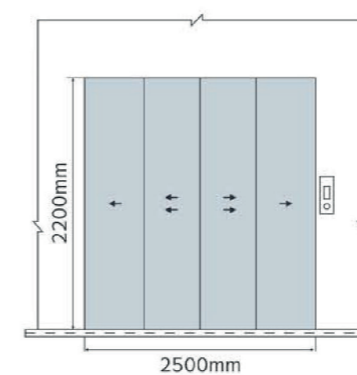

Center Opening Automatic Landing Door

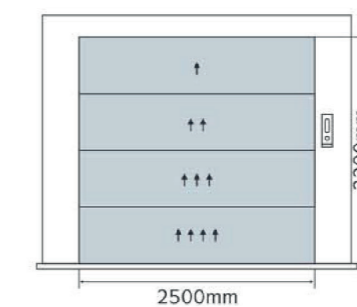

Vertical Opening Automatic Landing Door

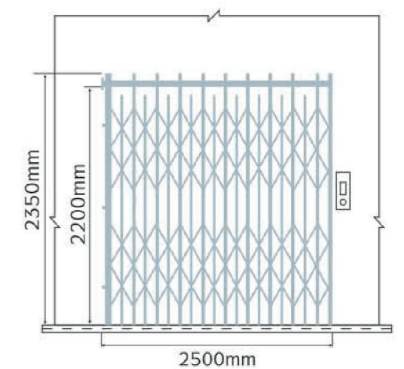

Collapsible Landing Door





## MRL Elevator

Machine Room-Less (MRL) lifts are traction elevators that feature a compact motor drive mounted on the car itself. They don't require to build a separate elevator machine room, MRL lifts allow you architectural flexibility, but they also provide fast, powerful and energy-efficient transportation. Though traction lifts were originally limited to high-rises, the innovative MRL design has allowed engineers to adapt traction elevators for low-rise buildings and multi-story homes.

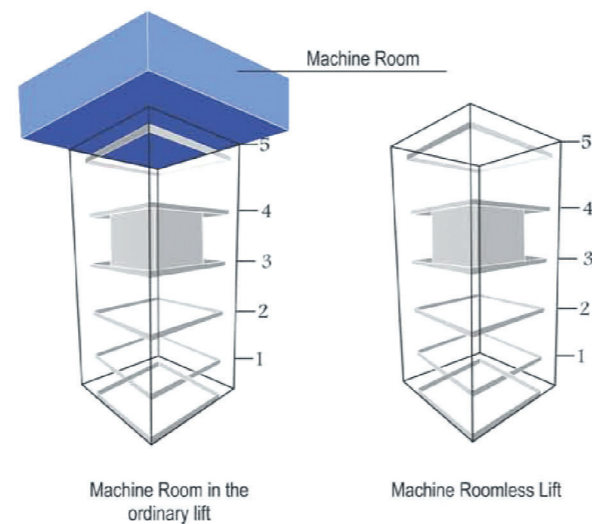

**It saves 25% of total elevator equipment area.  
It reduces 400/0 of space occupation.**

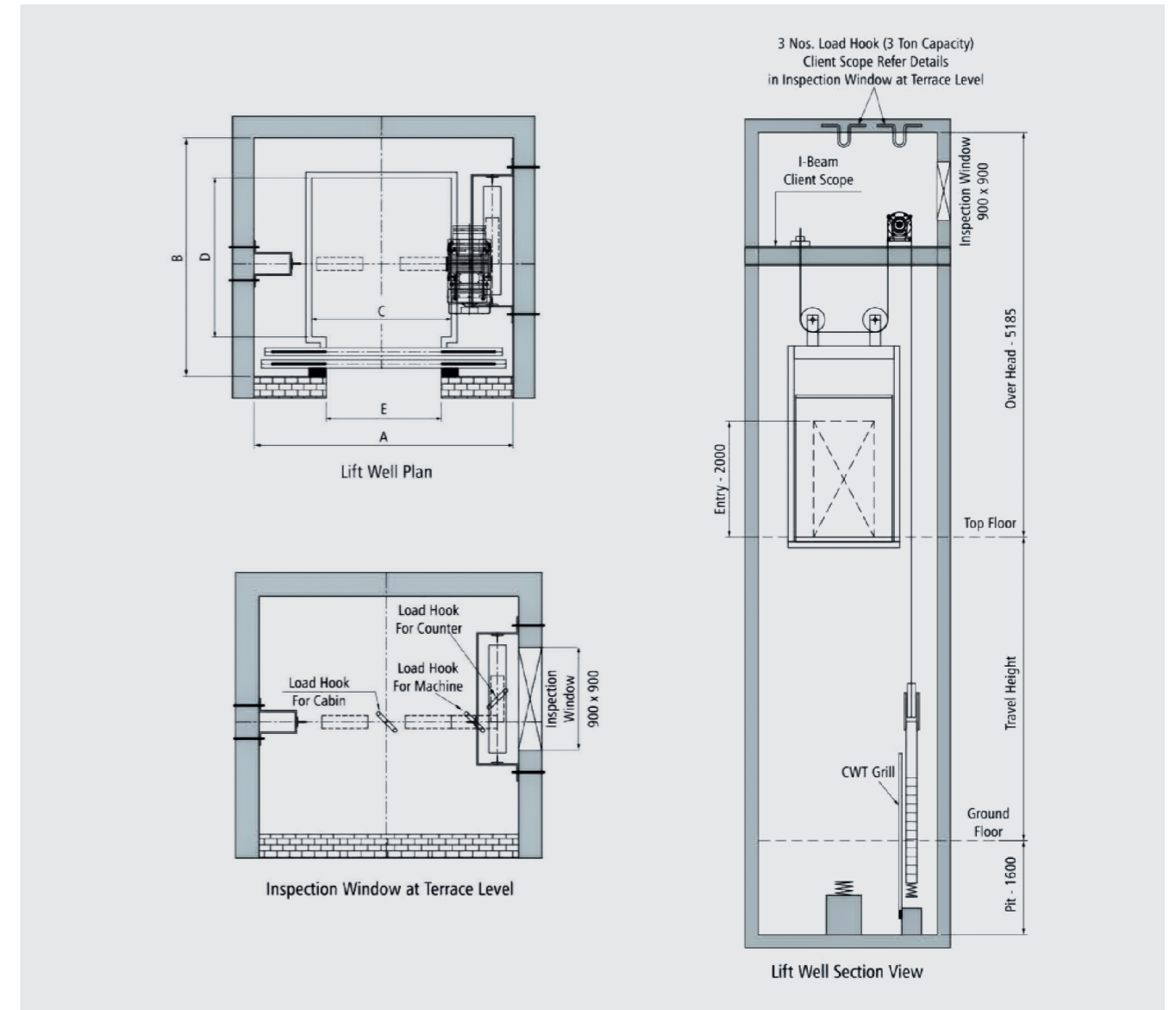

## Advantages of MRL elevators:

- » Permanent Magnet Gearless Machine for smooth and quiet motion.
- » 0.5 m/s to 4 m/s speed range (180 starts per hour).
- » 10 to 16 passenger load range (680 - 1088kg).
- » Smooth ride, due to the first-class roller shoe suspension.
- » Versatile landing and car door configurations.
- » Earthquake-friendly jugged guiding.
- » Small control cabinet on the upper level.
- » Totally integrated system for greater reliability.
- » Time and money-saving benefits: long lifespan, low operating cost, easy installation and service.
- » Cost-efficient elevator application, No machine room.





## Home Elevator

Home elevators not only increase the value of your home, but can also provide you stunning showpiece. At the same time, home lifts can allow the disabled and elderly to easily move about a multi-level dwelling. The term "home elevator" commonly refers to a lift enclosed in a shaft, and which can travel vertically as much as 15 m. (50 ft.). Home elevators make it easier to carry groceries, laundry or anything else from one floor to another. And today, they're fully customizable - choose from a wide range of materials, such as marble walls or stained glass, to turn your home elevator into an expression of your own unique style!

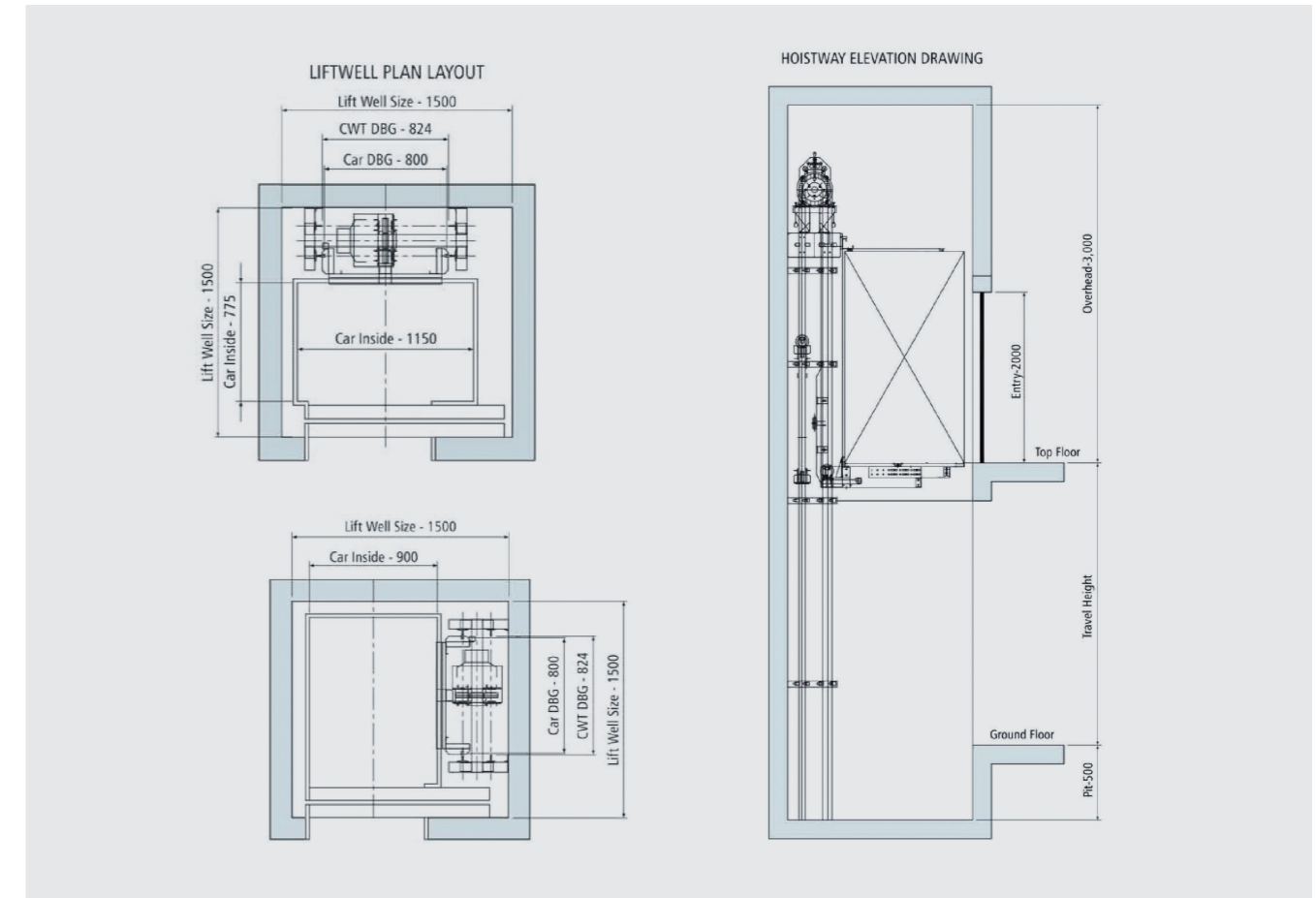

## Advantages of MRL elevators:

Our home elevators are driven by a Permanent Magnet Gearless Machine. Only available until recently on high-end commercial elevators, this technology delivers extremely smooth, noiseless motion. No need to worry about being disturbed by the noise of the elevator in your living space!

Multiple safety components (such as low-speed shaft braking and electrical dynamic braking) act either separately or combined, to provide the highest level of safety in the industry

Our home elevators are featured Machine Room-Less (MRL) design. They take up no additional space other than the hoist way.

Our home elevator do not needs overhead.

Home elevator designs range from the most basic, unfinished open platform, to a fully enclosed cabin with safety gates and an interior finish constructed of hardwood, ceramic tile, marble or granite. The enclosed design uses standard interior doors, to blend in seamlessly with your homes décor.

Your home elevator comes fully equipped with automatic controls and safety features like an emergency stop button, in-cab alarm, and a telephone jack that accommodates a standard household phone.



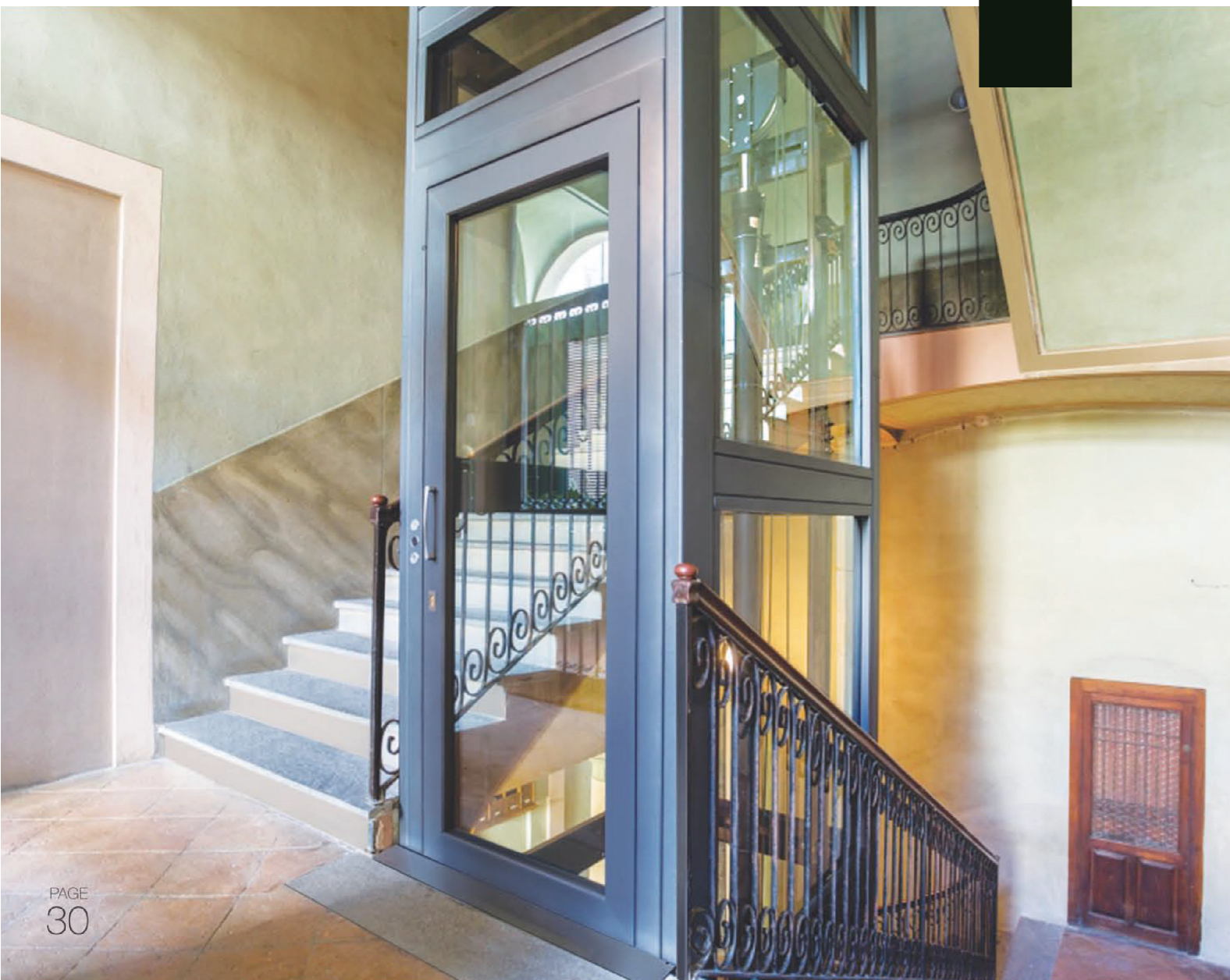

## Gulf hydraulic lifts gives you:

- » Safe, secure and powerful vertical transportation.
- » Low installation and maintenance cost compared to a traction lift.
- » A longer operating lifetime.
- » Comfort and low noise.
- » Simple & fast installation.
- » Single-time phase-3 power (for ascending) and phase-I (for descending).
- » Low unit cost, even with minimal inventory.

## Advantages & Benefits

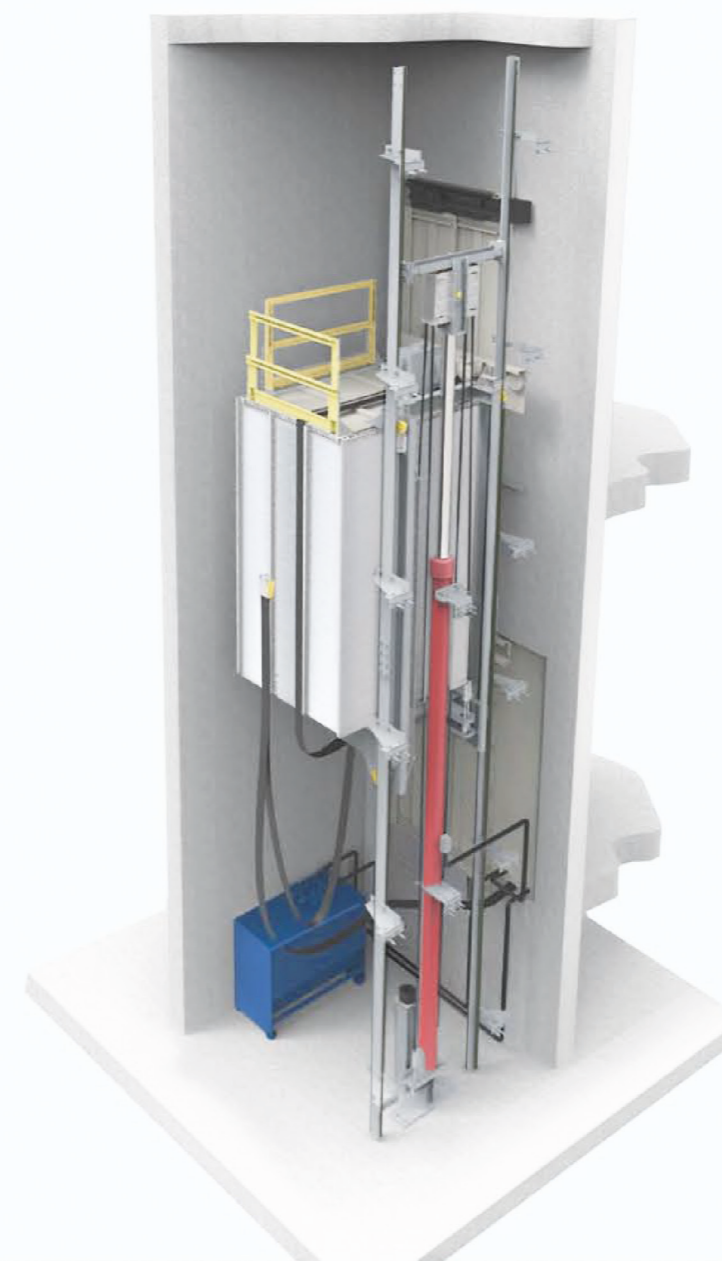

Machine Room Not Required



No Maintenance.



Power Saving



Electric Power Not Required in Down Direction.



100% Safe System.



Easy & Fast Installation.

## Hydraulic Elevator

Looking for a low-maintenance elevator? Hydraulic lifts provide the advantages of being relatively inexpensive, safe and easy to maintain. They're very convenient and cost-effective solution for low-rise buildings with low traffic. Hydraulic elevators have been rated the safest option for home elevators. They boast superb user friendliness and easy access machine room located at the basement. Once they are put in place, hydraulic elevators provide the smoothest rides possible.



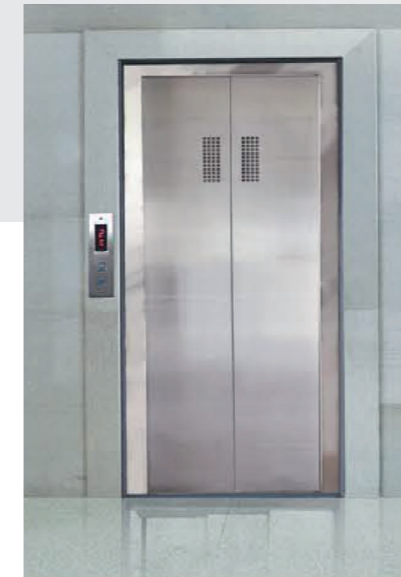

Center Opening Auto Door  
(Small Vision)



Center Opening Auto Door  
(Big Vision)

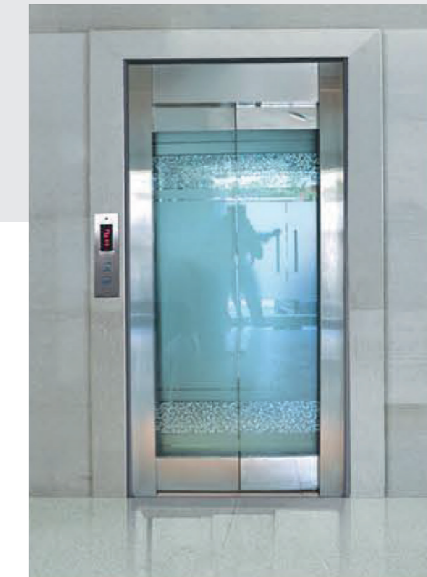

Full Glass  
Auto Door



Center Opening  
Auto Door

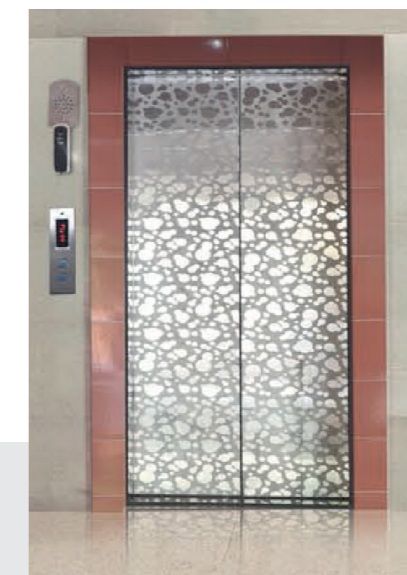

Center Opening Autodoor  
(Designer Finish)



Center Opening Auto Door  
(Four Panel )

## Automatic Door Series

The automatic doors at grocery stores and office buildings mainly exist for convenience, The automatic doors in an elevator, on the other hand are absolutely essential - they keep people from falling down an open shaft. Elevators use two different sets of doors: doors on the cars and doors opening into the elevator shaft. The doors on the cars are operated by an electric motor, which in turn is operated by the elevator computer.



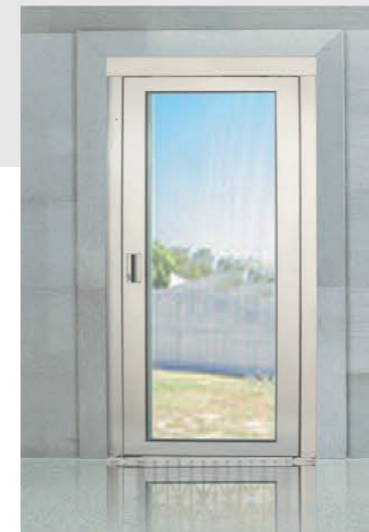
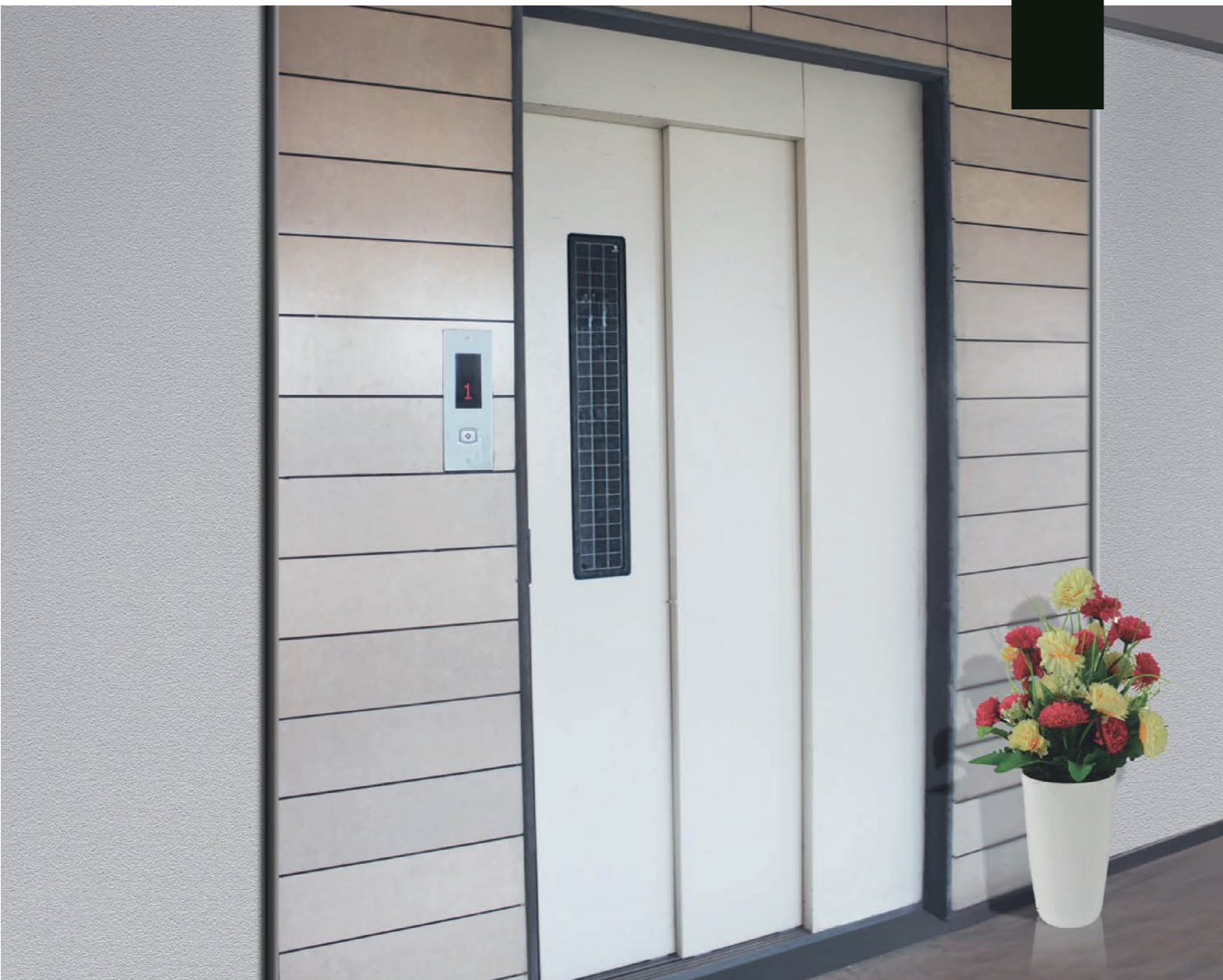

Manual Full Glass Door

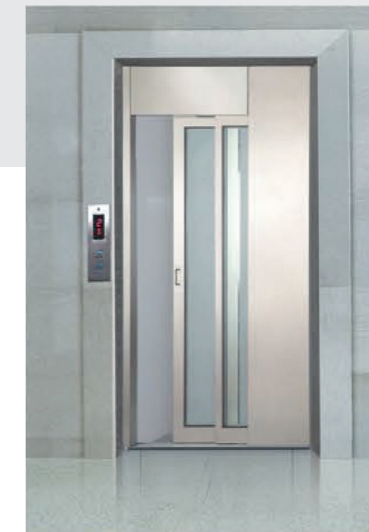

Manual Sliding Glass Door

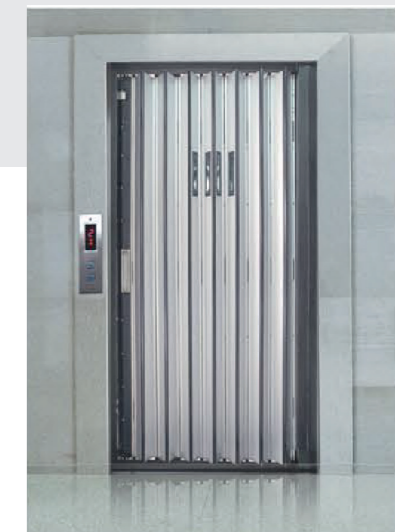

Imperforated Door



S.S. Two Fold Telescopic Door

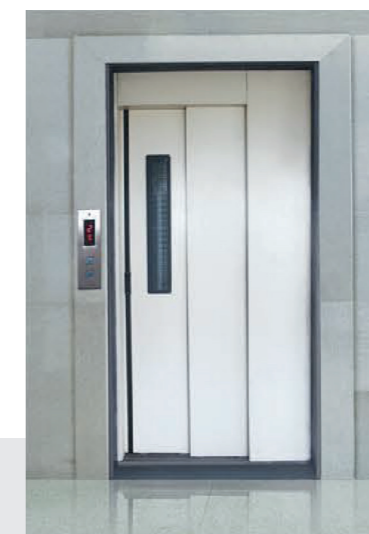

M.S. Two Fold Telescopic Door



M.S. Swing Door

## Manual Door Series

In the elevators, using two different sets of doors: doors on the cars and doors opening into the elevator shaft. The doors on the cars are operated by an electric motor, which in turn is operated by the elevator computer. In a relatively short period of time, elevators have become essential to urban life. As people continue to erect monumental skyscrapers and make small buildings handicap-accessible, elevators will become an even more pervasive element in society. It is truly one of the most important - and useful - machines of the modern era.



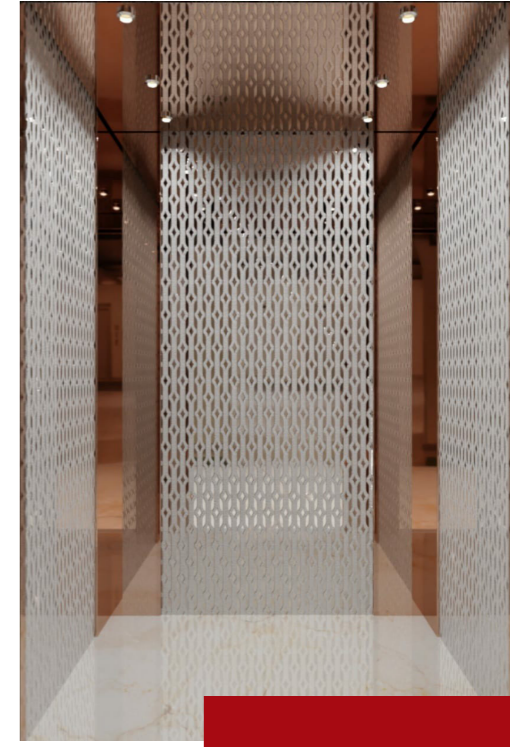
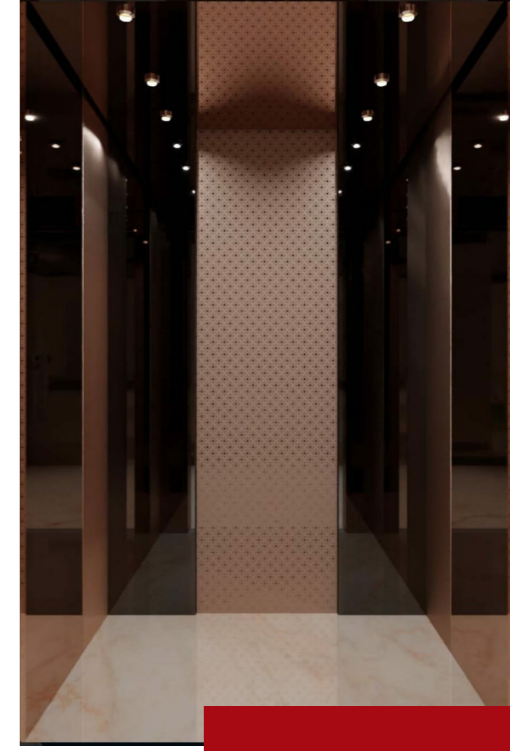
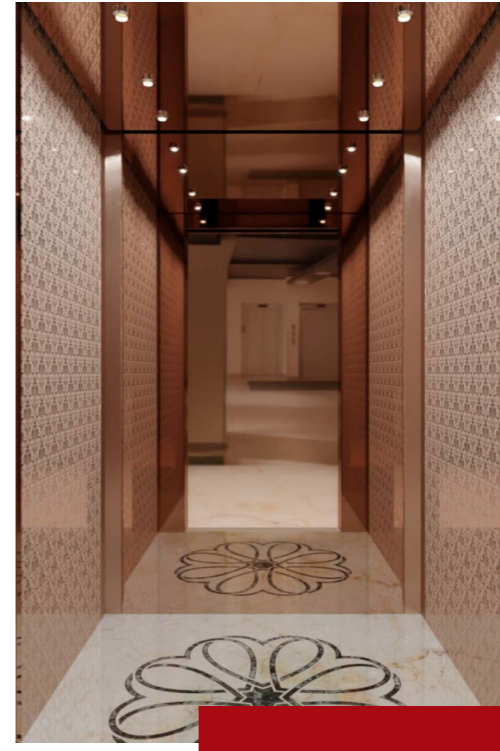
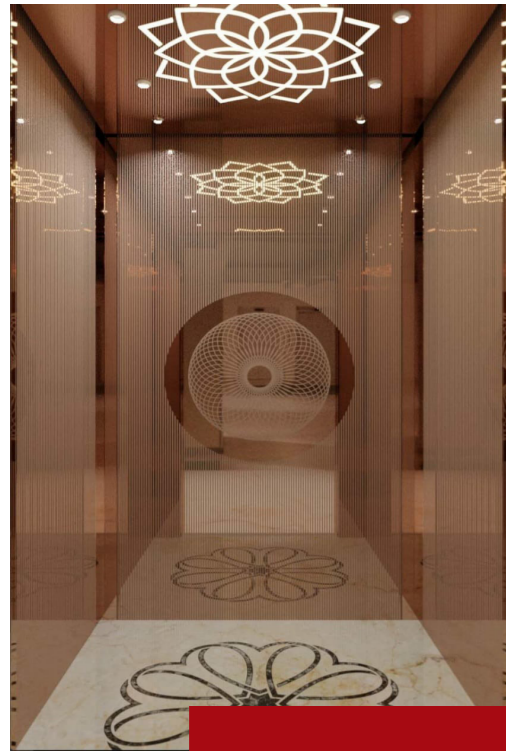

AN ISO 9001:2008 COMPANY



**GULF**<sup>TM</sup>  
**ELEVATORS**  
From Excellence to Perfection



## GET IN TOUCH



 [gulfelevatorsales@gmail.com](mailto:gulfelevatorsales@gmail.com)

 7405899998 / 9825824545

 [www.gulfelevatorsindia.com](http://www.gulfelevatorsindia.com)

 323,324 - Nakshtra -5 commercial complex, Opp  
Raj palace, sadhuvaswani Road , Rajkot -360005